

shown by tests on standard mononucleotides. A solution of 32 micromoles of the synthetic nucleoside diphosphates in 1 cc. of water was added to 16 cc. of tris-(hydroxymethyl)-aminomethane buffer (*pH* 7.6) containing 1 cc. of enzyme preparation and the mixture incubated at 37°. Ion-exchange analyses by the standard procedures were carried out on aliquots withdrawn at intervals. In the case of uridine diphosphate,³⁰ after 16 hours 43.6% and after 40 hours 51.5% of the diphosphate had been degraded to the monophosphate, no nucleoside being formed. In the case of cytidine diphosphate³⁰ after 16 hours 23.8%, after 40 hours 37% and after 64 hours 39% of the diphosphate had been converted to the monophosphate and 13.3% to cytidine. The identification of the monophosphates as the 5'-phosphates was established by ion-exchange procedure similar to the one described above under uridine-5'-phosphate.

Paper Chromatography of Uridine and Cytidine Diphosphates.—The solvent system isopropyl alcohol-1% ammonium sulfate (2:1, v./v.), using Whatman filter paper 1 previously soaked in 1% ammonium sulfate solution and dried, was found to be completely satisfactory in the present

(30) Cf. ref. 22, p. 539. Uridylic acid *b* is degraded more rapidly than cytidylic acid by the nucleotidase.

investigation; R_f values: uridine, 0.64; uridine-5'-phosphate, 0.45; uridine-2'(3')-5'-diphosphate, 0.34; cytidine, 0.51; cytidine-5'-phosphate, 0.38; cytidine-2'(3'),5'-diphosphate, 0.22. A second solvent system also found useful, especially for the separation of inorganic phosphate from the nucleotides is that of Ebel³¹ isopropyl alcohol (75 cc.)-water (25 cc.)-trichloroacetic acid (5 g.)-ammonia (sp. gr., 0.9); 25 cc. R_f values: inorganic phosphate, 0.68; uridine and cytidine diphosphates, around 0.32.

Acknowledgments.—This work was carried out under a consolidated grant from National Research Council of Canada, Ottawa. We wish to thank Dr. C. A. Dekker for many helpful discussions on this and related problems, Dr. J. B. Nielands for performing an electrometric titration and Mr. E. H. Pol for technical assistance during most of this work. Gratitude is expressed to Dr. G. M. Shrum for his generous encouragement of this work.

(31) J. P. Ebel, *Bull. soc. chim. (France)*, 991 (1953).

VANCOUVER 8, B. C.

[CONTRIBUTION FROM THE DEPARTMENT OF CHEMISTRY, BOSTON UNIVERSITY]

The Oxidation of Glucose by Chlorine in Acid Aqueous Solution¹

BY NORMAN N. LICHTIN AND MELVIN H. SAXE²

RECEIVED JULY 27, 1954

Although the reaction of glucose with chlorine in aqueous solution buffered at *pH* 2.2 by H_3PO_4/NaH_2PO_4 proceeds beyond the gluconic acid stage, the kinetics of reaction to this stage has been investigated through utilization of glucose in great excess. In order to prevent errors arising from the volatility of chlorine in acid solution, a convenient syringe-reactor technique has been devised. Variation of specific rate, both during the course of a reaction and with change in initial concentration of oxidant, added chloride ion and hydrogen ion, leads to the conclusion that Cl_2 is much more reactive than $HOCl$. At *pH* 2.2 the reaction follows the rate law: $v = k_2(Cl_2)(\text{glucose})$. For anomerically equilibrated glucose at 35.7°, k_2 is approximately 15 liters mole⁻¹ hr.⁻¹. At a *pH* of 3, the specific rate increases with increased buffer concentration. An analogous phenomenon is discernible in prior work with aqueous bromine.^{9,32} A mechanism consistent with the data involves attack of a base on a complex of halogen and carbohydrate.

Introduction

Earlier studies³ of the oxidation of D-glucose and other simple carbohydrates by aqueous solutions of halogens have been largely devoted to bromine water. These have demonstrated that initial reaction is to the D-gluconic acid stage in strongly acid,⁴ alkaline,⁵ or buffered feebly acidic⁶ media. Under the latter conditions the primary identifiable product is D-glucono- δ -lactone,⁷⁻⁹ Br_2 is the active component of bromine water⁹ and β -D-aldoses react more rapidly than their respective α -anomers.¹⁰ With excess unbuffered bromine water further oxidation occurs very slowly to yield 5-keto-D-gluconic acid¹¹ along with lesser amounts of D-glucaric acid.¹²

Meager available information suggests that reaction with aqueous chlorine follows a course similar to that with bromine. Thus D-glucose yields D-gluconic acid in both acidic¹³ medium and alkaline⁵ solution, but at a slower rate and in poorer yield than with bromine. Unlike bromine, unbuffered chlorine water attacks D-gluconic acid rapidly.¹⁴

The most significant studies involving aqueous chlorine have been devoted to its action in unbuffered solution on various glycosides. The reaction with methyl α - and β -D-glucoside¹⁵ is slower than with glucose, yet it proceeds initially to the D-gluconic acid stage, with 5-keto-D-gluconic acid¹⁶ and D-glucaric acid¹⁶ being formed subsequently. Analogous primary reactions have been established for methyl α - and β -D-galactoside, mannoside, xyloside and β -D-cellobioside.^{16,17} In all these cases oxidation is not preceded by hydrolysis¹⁵⁻¹⁷ and the β -glycosides react more rapidly than the respective α -anomers.^{15,17}

Since initial attack by chlorine takes place solely at the acetal carbon of the relatively unreactive gly-

(1) Based on a dissertation submitted by Melvin H. Saxe in partial fulfillment of the requirements for the degree of Doctor of Philosophy.

(2) Kendall Company Fellow 1949-1952.

(3) J. W. Green, "Advances in Carbohydrate Chemistry," Vol. III, Academic Press, Inc., New York, N. Y., 1948, pp. 129-184.

(4) H. Kiliani and S. Kleeman, *Ber.*, **17**, 1296 (1884).

(5) M. Honig and F. Tempus, *ibid.*, **57**, 787 (1924).

(6) C. S. Hudson and H. S. Isbell, *THIS JOURNAL*, **51**, 2225 (1929); *J. Research Natl. Bur. Standards*, **3**, 57 (1929).

(7) H. S. Isbell and C. S. Hudson, *ibid.*, **8**, 327 (1932).

(8) H. S. Isbell, *ibid.*, 615.

(9) H. S. Isbell and W. W. Pigman, *ibid.*, **10**, 337 (1933).

(10) H. S. Isbell and W. W. Pigman, *ibid.*, **18**, 141 (1937).

(11) J. P. Hart and M. R. Everett, *THIS JOURNAL*, **61**, 1822 (1939).

(12) J. P. Hart, F. Sheppard and M. R. Everett, *J. Biol. Chem.*, **123**, lii (1938).

(13) H. Hlasiwetz and J. Habermann, *Ber.*, **3**, 486 (1870).

(14) H. H. Fletcher and T. C. Taylor, *THIS JOURNAL*, **60**, 3018 (1938).

(15) A. Dyfverman, B. Lindberg and D. Wood, *Acta Chem. Scand.*, **5**, 253 (1951).

(16) A. Dyfverman, *ibid.*, **7**, 280 (1953).

(17) B. Lindberg and D. Wood, *ibid.*, **6**, 791 (1952).

cosides, it can be concluded that initial reaction with glucose is selective and occurs at the hemiacetal carbon. The present work has been largely devoted to an investigation of the kinetics of this reaction.

Experimental

Apparatus.—The volatility of chlorine in acid aqueous solution is so great that ordinary analytical procedures cannot be employed. This problem has been overcome previously but by cumbersome means.^{18,19} A more convenient procedure employs as the reaction vessel a hypodermic syringe provided with an adapter (Fig. 1) attached by means of a ground joint. This permits all but a very small portion of the reaction mixture to remain thermostated throughout a run so that, by discarding the contents of the adapter before taking a sample, effective temperature control is assured. The delivery of samples beneath the surface of aliquots of arsenite solution eliminates evaporation losses completely. The syringe and adapter were painted black in order to prevent photochemical complications. Aliquot sizes were determined by weighing. Reliability of the sampling procedure was established as better than $\pm 1\%$ by analyzing successive portions of charges of chlorine water. The density of that portion of the reaction mixture remaining at the end of each run was measured with a Mohr-Westphal balance.

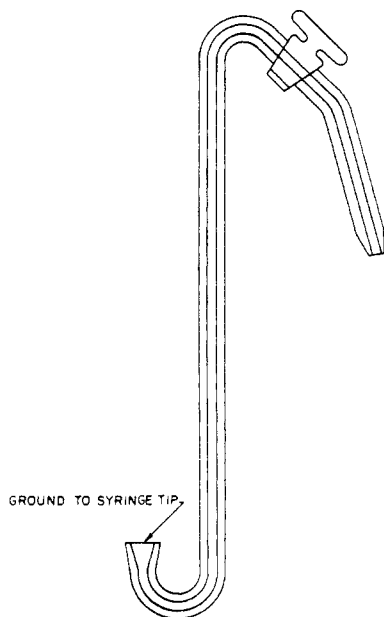

Fig. 1.—Adapter for syringe reactor.

Analyses.—The sum of the concentrations of the components of aqueous chlorine (stoichiometric chlorine), *i.e.*, dissolved chlorine, hypochlorous acid and hypochlorite ion, were determined by reducing with excess $N/100$ sodium arsenite solution and back-titrating to a starch end-point with $N/100$ iodine in the presence of solid sodium bicarbonate.²⁰

Glucose was determined by the anthrone method.²¹ Color was measured at $620 m\mu$ with a Klett-Summerson colorimeter (No. 6618) equipped with a Baird 7-3231-5 interference filter and a Corning 3486 absorption filter. The ability of the method to discriminate between glucose and its oxidation products was established by analyzing aliquots of a kinetic experiment with glucono- δ -lactone as reductant.

Chloride ion formed by processes other than hydrolysis of aqueous chlorine was determined from the difference between the stoichiometric concentration of chlorine and the

concentration of chloride ion (Volhard) present after reducing an aliquot with sodium arsenite in the presence of solid sodium bicarbonate.

The pH of that portion of the reaction mixture remaining at the end of each run was measured by means of a glass electrode (Leeds and Northrup pH meter No. 7662). Failure to thermostat the electrode cup reduced the accuracy of these measurements since the pH of the buffer solution (approximately 0.30 molar in H_2PO_4 and 0.31 molar in NaH_2PO_4) varied from 2.09 at 27.0° to 2.19 at 35.7° in agreement with the known temperature dependence of the ionization of H_2PO_4 .^{22,23}

Kinetics and Stoichiometry.—In the majority of experiments a weighed sample of glucose was dissolved in a weighed portion of thermally equilibrated, buffered chlorine water. The instant of addition of glucose was taken as zero time in kinetic experiments, any evaporative loss of oxidant prior to this addition being irrelevant to the subsequent measurements. A convenient quantity of homogeneous solution was then rapidly drawn into the thermally equilibrated syringe-reactor. Experimental points were taken over about 90% of reaction.

In an alternative procedure (run 17 and all those labeled I in Table IV) glucose was dissolved in buffer and equilibrated thermally and anomerically. An aliquot of thermally equilibrated chlorine water was then added rapidly (time of addition being taken as zero time) and the homogeneous solution quickly drawn into the syringe reactor. In experiments labeled I only the first 10 to 15% of the reaction was followed (eight experimental points).

In stoichiometric work aliquots to be subjected to the anthrone procedure were quenched in the usual way, treated with sodium bicarbonate and allowed to stand overnight. The pH was then adjusted to 4 to 6 with acetic acid and the aliquot diluted with water to 100 ml. before being subjected to analysis.

Reagents.—Glucose was Merck C.P. anhydrous grade and was found polarimetrically to be almost entirely α . Glucono- δ -lactone (Pfizer) was dried at 110° for 1 hour; $[\alpha]^{25}_D + 63.2^\circ$ 6 minutes after dissolution (1.2527 g. in 25 ml. H_2O); Fehling test was negative on boiling; silver nitrate and Beilstein tests were negative; color corresponding to 0.2% of glucose-active material developed with anthrone reagent. Chlorine water was prepared with exclusion of light and stored under refrigeration in the dark for as long as two months.

Data

The reliability of the data for purposes of chemical interpretation was evaluated by several experiments.

Blank runs corresponding to the majority of experiments revealed that the stoichiometric chlorine concentration decreased less than 1% during periods corresponding to kinetic runs extending to 90% consumption and by about 5% in 24 hours. No further decrease ensued during the following 24 hours. No evidence was detected of catalysis of decomposition of aqueous chlorine by sodium chloride, buffer components or sodium sulfate.²⁴ Although the concentration of unbuffered chlorine water decreased drastically on prolonged refrigerated storage in the dark, there was only a minor accompanying accumulation of chloride ion.²⁵ Apparently most of the observed decrease in stoichiometric chlorine was due to vaporization.

That anomerically equilibrated glucose constituted the reductant was demonstrated by observing that mutarotation in standard buffer at 35.7° was ten to one hundred times as fast as consumption of

(22) A. A. Noyes, *THIS JOURNAL*, **30**, 349 (1908).

(23) L. F. Nims, *ibid.*, **56**, 1110 (1934).

(24) Compare ref. 3, pp. 136-137.

(25) In a relatively unfavorable case, during a 28-day period non-hydrolytic chloride ion increased from 1.4×10^{-3} to 2.0×10^{-3} mg. ion per gram of solution while stoichiometric chlorine decreased from 44.1×10^{-3} to 23.7×10^{-3} meq. per gram of solution.

(18) J. Groh, *Z. physik. Chem.*, **81**, 695 (1913).

(19) F. O. Rice and C. F. Fryling, *THIS JOURNAL*, **47**, 379 (1925).

(20) R. M. Chapin, *ibid.*, **56**, 2211 (1934).

(21) F. J. Viles, Jr., and L. Silverman, *Anal. Chem.*, **21**, 950 (1949).

chlorine and that kinetic data with glucose pre-equilibrated in buffer were in agreement with those obtained with simultaneous dissolution of glucose and exposure to chlorine (Table IV, runs 17 and I-17).

Stoichiometry.—The dependence of stoichiometry on time is indicated by the data of Table I. The blank loss of chlorine for a parallel experiment with a similar initial concentration was 4.2% in 25.17 hours and a total of 4.3% in 50.35 hours. Although a rigorous correction cannot be applied to the data of Table I, it is clear that the ratios chlorine consumed: glucose consumed are all somewhat greater than they would be in the absence of chlorine consumption not related to glucose and its oxidation products. It nevertheless can be concluded that the oxidation to the gluconic acid state is slower than the second step and that extensive further oxidation occurs but at a rate considerably slower than that of the initial attack on glucose.

TABLE I
STOICHIOMETRY^a AT 35.7°

Time, hr.	Chlorine concn., ^b mmole/g. × 10 ³	Glucose concn., mmole/g. × 10 ³	Moles chlorine consumed per mole glucose consumed
0.10	30.9	3.27	..
2.57	29.7	2.68	2.0
7.57	28.3	1.79	1.8
15.47	25.4	0.92	2.3
24.10	23.2	.51	2.8
48.45	16.6	.03	4.4
74.02	12.8	.00	5.5

^a Concn. of buffer (moles/kg. of soln.): NaH₂PO₄, 0.302; H₃PO₄, 0.288. ^b Not corrected for blank loss.

Kinetics.—Rate data were collected at 35.7° for solutions in which the initial molar ratio glucose: chlorine varied from 18.5 to 78. A standard initial concentration of glucose, namely, 0.444 mole per kilogram of solution was generally employed and small deviations corrected on the basis of an order of unity in this reactant (*vide infra*). The data of a typical run are assembled in Table II in the form of time *vs.* concentration, integrated first-order rate constants and instantaneous specific rates, respec-

TABLE II
KINETIC DATA FOR RUN 7^a

Time, hr.	Concn. of oxidant, meq./g. soln. × 10 ³	First order rate integrated ^b k_{1i} , hr. ⁻¹	Instantaneous ^c k_{1i} , hr. ⁻¹	$1 - \alpha$ ^e	$\frac{k_{1i}}{1 - \alpha}$, hr. ⁻¹
0.00	2.94 ^d	0.70 ^d	0.66 ^d	0.094	7.0
.13	2.68	.71	.71	.101	7.0
.37	2.26	.71	.78	.116	6.7
.48	2.04	.77	.82	.122	6.7
.65	1.75	.80	.87	.131	6.6
.85	1.47	.82	.93	.140	6.6
1.00	1.26	.85	.96	.147	6.5
1.33	0.89	.90	1.03	.158	6.5
1.65	0.63	.93	1.08	.166	6.5
2.00	0.44	.95	1.11	.173	6.4
2.33	0.33	.94	1.13	.175	6.5

^a At 35.7°; buffer concn.: H₃PO₄, 0.265 mole/kg. soln.; NaH₂PO₄, 0.278 mole/kg. soln. ^b From $k = \frac{2.303}{t} \log \frac{(Ox)_0}{(Ox)}$. ^c From $k = \frac{d(Ox)/dt}{(Ox)}$. ^d By extrapolation. ^e $1 - \alpha = \frac{(Cl_2)}{(Ox)}$; calculated by means of equation 3 with $R = 0.129$ mole/kg. soln.

tively. In order to calculate the pseudo first-order constants from the integrated rate expression, it is necessary to evaluate $(Ox)_0$, the initial stoichiometric concentration of chlorine. This was accomplished by extrapolation of $\log(Ox)$ to zero time using only the first two experimental points. The instantaneous pseudo first-order specific rates were obtained from the smooth curve of (Ox) *vs.* time with the aid of a Bausch and Lomb prism tangentimeter. The tabulated initial rate values $(k_1)_0$ were obtained by linear extrapolation of plots of integrated and instantaneous specific rate constants, respectively, *vs.* time. Initial rate constants similarly obtained for runs which differed only in initial stoichiometric concentration of oxidant are listed in Table III and their linear dependence on the

TABLE III
DEPENDENCE OF INITIAL RATE ON OXIDANT CONCENTRATION^a

Run	$(Ox)_0$, ^b meq./g. soln. × 10 ³	Initial pseudo first-order rate, hr. ⁻¹		$1 - \alpha_0$ ^c	$\frac{(k_1)_0}{1 - \alpha_0}$
		Integrated $(k_1)_0$	Instantaneous $(k_1)_0$		
4	1.08	0.39	0.39	0.039	10.0
7	2.94	.70	.66	.094	7.4
3	3.33	.79	..	.104	7.6
6	4.44	.99	.91	.130	7.6

^a At 35.7°; buffer concn. (moles/kg. of soln.): NaH₂PO₄, 0.278; H₃PO₄, 0.268. ^b Initial stoichiometric concn. of oxidant determined by extrapolation. ^c $1 - \alpha_0 = \frac{(Cl_2)_0}{(Ox)_0}$. Calculated by means of eq. 3 with $R = 0.129$ mole/kg. soln.

initial concentration is illustrated by Fig. 2. Where initial rates were determined, both $(Ox)_0$ and $(k_1)_0$ were obtained directly from the linear plots of $\log(Ox)$ *vs.* time.

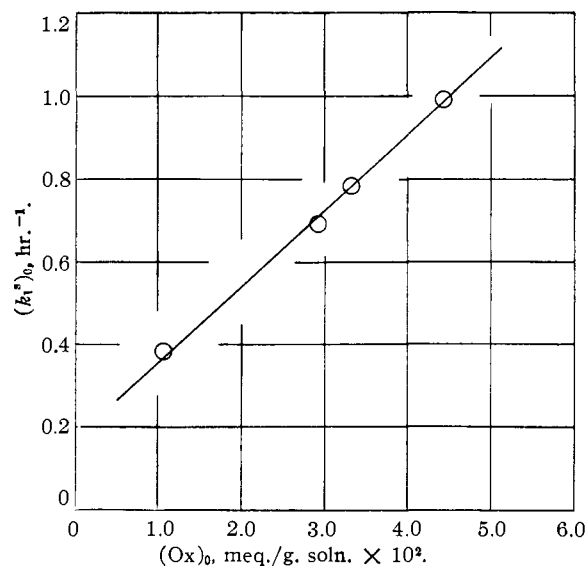
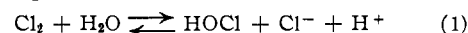

Fig. 2.—Initial pseudo first-order specific rates (by extrapolation of integrated data) *vs.* initial oxidant concentration.

Consideration of the hydrolytic equilibrium of chlorine (equation 1)



provides an explanation of the observed variation

in the initial pseudo first-order specific rates with initial stoichiometric concentration of oxidant and of the increase in rate during a single run. Assuming that hydrolysis is the sole source of initially present chloride ion, it is clear that, at constant pH , the fraction of total oxidant present initially as Cl_2 increases with increasing initial stoichiometric concentration of oxidant. It thus appears that Cl_2 is more reactive than $HOCl$. It can also be demonstrated that the fraction of total oxidant present as Cl_2 increases during the course of the reaction in agreement with the observed rate increase. Thus, with $\alpha = (HOCl)/(Ox)$, $1 - \alpha = (Cl_2)/(Ox)$; $(Cl^-) = 2[(Ox)_0 - (Ox)] + (HOCl) + m$, where m = concentration of added chloride ion, the equilibrium relationship at constant pH is represented by equation 2.

$$R = \frac{K}{(H^+)} = \frac{\alpha[\alpha(Ox) + 2(Ox)_0 - 2(Ox) + m]}{1 - \alpha} \quad (2)$$

Here, R and K are concentration equilibrium constants. Solution of this expression yields equation 3

$$\alpha = \frac{-B + [B^2 + 4R(Ox)]^{1/2}}{2(Ox)} \quad (3)$$

where $B = 2(Ox)_0 - 2(Ox) + R + m$. The value of R can be estimated with fair accuracy from available thermodynamic data on the hydrolysis of chlorine.²⁶ From these, the thermodynamic equilibrium constant at 35.7° is found to be 6.55×10^{-4} (equation 4).

$$\frac{(HOCl)(H^+)(Cl^-)\gamma_{HOCl}\gamma_{H^+}\gamma_{Cl^-}}{(Cl_2)\gamma_{Cl_2}} = 6.55 \times 10^{-4} \quad (4)$$

It can reasonably be assumed that $\gamma_{HOCl}/\gamma_{Cl_2}$ equals unity even at the 0.3 molal ionic strength of the buffer. The product $\gamma_{H^+}\gamma_{Cl^-}$ equals γ_{\pm} for HCl . Interpolating the data²⁷ for HCl in solutions of $NaCl$, γ_{\pm} at the ionic strength of the buffer and 0.01 molal HCl may be taken as 0.74. This yields $R = 1.20 \times 10^{-3}/(H^+)$. The pH of reaction mixtures in standard buffer as measured directly with a glass electrode was 2.2, corresponding to a_{H^+} of 6.3×10^{-3} molal. For purposes of estimating γ_{H^+} it was assumed²⁸ that $\gamma_{Cl^-} = \gamma_{K^+}$ in 0.3 molal solutions of KCl . Thus, from the available values of γ_{\pm} for KCl ²⁹ and γ_{\pm} for HCl , γ_{H^+} may be taken as 0.79. This yields 0.150 mole per kilogram of water as the value of R . For each run where R has been employed in calculation it has been further converted to the appropriate units, *i.e.*, moles per kilogram of solution. The values of $1 - \alpha$ calculated in this way for run 7 are tabulated in the fifth column of Table II. Knowledge of α as a function of stoichiometric oxidant concentration permits estimation of $k_1^{Cl_2}$ and k_1^{HOCl} , the individual specific pseudo first-order rates for attack by Cl_2 and $HOCl$, respectively. If $HOCl$ is inert, $k_1^{Cl_2} = k_1^i/(1 - \alpha)$, where k_1^i is the

experimental instantaneous specific rate corresponding to a given α . The approximate constancy of $k_1^i/(1 - \alpha)$ throughout a single run (sixth column of Table II) indicates that $HOCl$ contributes little to the reaction. A similar conclusion may be drawn from the analogous treatment of the initial rates of several runs (Table III), although the data for run 4 suggest that $HOCl$ is not totally inert. An apparent value of k_1^{HOCl} can be obtained by graphical solution of the equation $k_1 = k_1^{HOCl}\alpha + k_1^{Cl_2}(1 - \alpha)$. Such a solution using values of $(k_1^i)_0$ from Table III yields $k_1^{Cl_2} = 7.7 \text{ hr.}^{-1}$ and $k_1^{HOCl} = 0.05 \text{ hr.}^{-1}$ but, in view of the uncertainties involved in estimating R and the presence of small initial concentrations of chloride ion not resulting from hydrolysis, little significance can be assigned to the latter figure and it can only be concluded that $HOCl$ reacts much more slowly than Cl_2 . Taking $k_1^{Cl_2}$ as 7 hr.^{-1} , with glucose at a concentration of 0.444 mole/kg. solution, the second-order rate constant for the reaction of chlorine at 35.7° is $16 \text{ kg. mole}^{-1} \text{ hr.}^{-1}$ or, since the solutions had a density of 1.074 g./ml., $k_2^{Cl_2}$ is 15 liters mole⁻¹ hr.⁻¹.

Data summarized in Table IV support some of the above conclusions and, in addition, provide information concerning salt effects and catalysis by acids and bases. The results of run I-17 indicate that the extrapolation procedure described above is reasonably accurate. Runs 9 and 10, with added chloride present at concentrations too low to sensibly alter the ionic strength or to convert a significant fraction of oxidant to trichloride ion,³⁰ proceeded at enhanced rates as would be expected from equation 1. In run 9 the integrated rate constants increased only 17% over 85% of reaction while in run 10 there was only random variation over the same period. These results would be

TABLE IV
SUMMARY OF INITIAL RATES

Run	(Ox) ₀ , meq./ g. soln.	Buffer ^b	Added substance, moles/kg. soln.	pH	Exptl. (k ₁ ⁱ) ₀ , ^c hr. ⁻¹	Std. (k ₁ ⁱ) ₀ , ^d hr. ⁻¹
17 ^e	0.0244	0.278; 0.954	2.2	0.56	0.62
I-17 ^a	.0203	.311; .926	2.1	.62	.55
9	.0449	.278; .954	0.0211 NaCl	2.2	1.39	.99
10	.0411	.278; .954	.0402 NaCl	2.2	1.53	.93
8	.0454	.274; .954	.0990 Na ₂ SO ₄	2.3	.94	1.00
20	.0335	.248; .954	.750 Na ₂ SO ₄	2.3	.67	.79
I-23 ^a	.0332	.302; .927	.288 KClO ₄	2.1	.93	.79
11	.0201	.410; .954	2.2	.64	.55
13	.0353	.282; .0842	3.0	.147	.83
15	.0236	3.15; .0841	3.05	.74	.61
I-28 ^a	.0208	0.0275; .967	.261 KClO ₄	1.5	1.48	.56
I-29 ^a	.0300	.258; .924	1.35	2.38	.73
I-24 ^{a,f}	.0332	.300; .926	2.1	.80	.78
I-53 ^{a,g}	.0349	.268; .926	2.1	.86	.81
19 ^h	.0292	.278; .954	2.2	1.16	.72

^a Experiments by G. J. Grillo involving initial rate measurements with glucose pre-equilibrated in buffer solution. ^b Composed of H₃PO₄ and NaH₂PO₄. The first figure cited is the concentration of the salt in moles/kg. soln.; the second is the molal ratio of acid to salt. ^c Unless otherwise indicated, by extrapolation of integrated rate constants to initial concentration; corrected for deviation from std. concentration of glucose on the basis of an order of unity. ^d By interpolation of Fig. 2. ^e With glucose pre-equilibrated in buffer solution. ^f Concn. of glucose: 0.251 mole/kg. soln. ^g Concn. of glucose: 0.800 mole/kg. soln. ^h Glucono- δ -lactone as reductant.

(26) G. N. Lewis and M. Randall, "Thermodynamics," McGraw-Hill Book Co., New York, N. Y., 1923, p. 508.

(27) H. S. Harned and B. B. Owen, "The Physical Chemistry of Electrolyte Solutions," Reinhold Publ. Corp., New York, N. Y., 1950, p. 575.

(28) D. S. McKinney, P. Fugassi and J. C. Warner, in "Symposium on pH Measurement," American Society for Testing Materials, Philadelphia, Pa., 1946, p. 20.

(29) Reference 27, p. 369.

(30) M. S. Sherrill and E. F. Izard, *THIS JOURNAL*, **53**, 1667 (1931).

expected from the buffering effect of added chloride on the hydrolytic equilibrium. Solution of equation 3 for α_0 for run 10 yields a value of 0.70. On the basis of $k_1^{Cl^-} = 7 \text{ hr.}^{-1}$ this leads to a value of $(k_1)_0$ of 2.1 hr.^{-1} . The agreement with the observed value of 1.53 hr.^{-1} is as good as might be expected on the basis of the several uncertainties both in calculation and experiment.

The data of runs 8, 20 and I-23 reveal a negligible salt effect and thereby support the interpretation of the influence of chloride ion. The results of runs 8 and 20 have an additional significance because SO_4^{2-} is a base of roughly the same strength as H_2PO_4^- and there is no evidence of appreciable catalysis by this ion.

The results of run 11 suggest an enhanced rate at higher buffer concentration and standard component ratio but the effect is marginal.³¹ The data of runs 13 and 15, however, unequivocally demonstrate a catalytic effect. A decreased rate would be expected at $p\text{H}$ 3.0 because of the effect on the hydrolytic equilibrium. With the aid of equation 3, a value of $(k_1)_0$ equal to 0.14 hr.^{-1} can be calculated for run 13 in (probably fortuitously) excellent agreement with the observed value. With a tenfold increase in buffer concentration at the same ratio and $p\text{H}$, however, the rate becomes at least as great as at $p\text{H}$ 2.2.

Runs I-28 and I-29, which were carried out at lower $p\text{H}$, proceeded at enhanced rates in accord with the expected shift in the hydrolytic equilibrium. These data do not, however, reveal any other significant influence of acid concentration. This can be deduced from the similarity of results at the two buffer concentrations. The agreement of the experimental initial rates of runs I-28 and I-29 with the values calculated by means of equation 3, namely, 1.6 and 2.8 hr.^{-1} , respectively, further substantiates the conclusion that enhancement of H_3PO_4 and H_3O^+ concentration does not produce any catalytic effect like that observed at higher $p\text{H}$.

An order of unity in glucose is demonstrated by the results of runs I-24 and I-53, which were carried out with glucose concentrations differing widely from the standard value. Correction of the observed pseudo first-order specific rates (0.45 and 1.56 hr.^{-1} , respectively) to standard glucose concentration on this basis gives rates in good agreement with the standard values.

Run 19, which employed glucono- δ -lactone proceeded at a rate somewhat faster than the corresponding standard rate with glucose. Since the rate of this run decreased slightly as it progressed, it can be concluded that free gluconic acid and its γ -lactone are probably less reactive than the δ -lactone. The observed rate can accordingly be taken as an upper limit to the reactivity of the sum of tautomeric acid and lactones which may be present in the reaction mixtures formed from glucose.

Discussion

It can be concluded from the assembled evidence that the rate data for glucose refer to conversion

(31) Experiments by G. J. Grillo have shown that with much higher buffer concentrations (*ca.* $3M$) the secondary salt effect is so large ($p\text{H}$ shifted to 1.05) that a unique interpretation of the observed enhancement in rate is not possible.

to the gluconic acid stage. It has been established that the principal effective oxidant is molecular chlorine and that the reaction is of the first order in this reagent and in glucose. The second-order rate constant represents a weighted mean, since anomeric equilibrium is maintained. If the reaction of α -glucose is taken as negligible^{9,10,15,17} k_2^β , the specific rate for β -glucose, is approximately 25 liters mole⁻¹ hr.⁻¹. The reaction rate, at a $p\text{H}$ of 2.3 or less, has been found to be virtually uninfluenced by perchlorate and sulfate ions and, aside from the influence of $p\text{H}$ on the hydrolytic equilibrium, by phosphoric acid and oxonium ion. At a $p\text{H}$ of 3, however, catalysis is observed which can be ascribed either to H_2PO_4^- ion or to some species derived therefrom.

The observed catalysis is consistent with observations on the behavior of aqueous bromine. Both in acid solutions³² and in solutions buffered with carbonate to a $p\text{H}$ of about 5-6,⁹ molecular bromine is the active oxidant in bromine water. Quantitative comparison of the data of Bunzel and Mathews³² with those of Isbell and Pigman⁹ reveals a pronounced catalytic effect. The former workers, employing bromine water containing 0 to 0.5 N added acid (HBr , HCl , H_2SO_4 , H_3PO_4) and excess preequilibrated glucose, obtained rate data at 25° which they corrected for formation of inert Br_3^- and Br_2Cl^- . Their results,³³ upon correction for relatively unreactive α -glucose, yield $k_2^\beta = 3.25$ liters mole⁻¹ hr.⁻¹ at 25°. Isbell and Pigman,⁹ employing $\text{BaCO}_3/\text{CO}_2$ as buffer ($p\text{H}$ 5-6) with pure β -glucose, obtained rate data which upon correction for formation of Br_2^- and Br_5^- yield a value of $k_2^\beta = 174$ liters mole⁻¹ hr.⁻¹³⁴ at 0.3°. This striking acceleration may be interpreted in terms of catalysis involving any or all of the species HCO_3^- , CO_3^{2-} and OH^- .³⁵

Any attempt at a complete mechanistic picture would be premature at this time but certain aspects can be discussed with profit. For this purpose, it is assumed that there is a fundamental similarity between the modes of action by aqueous chlorine and bromine.

Earlier work with bromine has demonstrated that the pyranose form of glucose is the reductant.⁷⁻¹⁰ This conclusion is buttressed by the fact that various methyl glycosides are oxidized by aqueous chlorine at C_1 more rapidly than they are hydrolyzed.¹⁵⁻¹⁷

The oxidizing species may be compared with reactants which have been identified in aromatic halogenation.³⁶ Studies in the latter field have revealed that not only X_2 , HOX and OX^- , but also

(32) H. H. Bunzel and A. P. Mathews, *THIS JOURNAL*, **31**, 464 (1909).

(33) Although Bunzel and Mathews do not state their units, it is apparent from their data that, for their pseudo first-order constants, these are min.⁻¹. The frequently referred to³³ observation by these workers of inhibition of oxidation by acids is not apparent in their rate constants corrected for inertness of Br_2Cl^- and Br_3^- (their K').

(34) Rate constants tabulated by these authors are apparently in units of liters mole⁻¹ min.⁻¹/2.303.

(35) The possibility exists that the analytically useful alkaline "hypoiodite" oxidation of simple carbohydrates (*cf.* ref. 3, p. 156) may actually be a reaction of molecular iodine catalyzed by OH^- or other basic reagents.

(36) *Cf.* C. K. Ingold, "Structure and Mechanism in Organic Chemistry," Cornell University Press, Ithaca, N. Y., 1953, pp. 288-295.

X^+ ,³⁷ H_2OX^+ , $XHPO_4^-$ ³⁸ and CH_3COX ³⁹ may be present in aqueous solutions of halogens under various conditions. In the present and earlier related work, Cl_2 and Br_2 have been found to be the major oxidants. The absence of catalysis in the acid range does not, however, rule out the possibility of detecting oxidizing action by H_2OX^+ or X^+ under more suitable conditions, e.g., with acidified pure HOX .³⁷ Molecular bromine and chlorine have also been identified as the active components of acid aqueous halogen in the oxidation of acetaldehyde^{13,40} and formate ion.^{18,41} In the oxidation of acid-oxalate ion, however, $HOCl$ and $HOBr$ are the active reagents.^{42,43}

The formation of acyl hypohalites constitutes a possible explanation of the catalytic effects observed in the present work and related studies with bromine.^{9,33} Catalysis by buffer components of aromatic bromination with $HOBr$, but not with Br_2 , has been observed and ascribed to formation of reactive intermediates of this type.^{38,39} In contrast to the present work this catalysis has in several cases been found to be due to the acid component of the buffer.^{38,39,44} However, $H_2PO_4^-$ has been observed to function as a bromination catalyst.³⁸ Catalysis of the oxidizing action of Br_2 by the components of carbonate buffer^{9,33} suggests that the mechanism of catalytic action is different from that evoked in aromatic bromination, not only because Br_2 is involved but because of the improbability that intermediates such as $BrOCO_2^-$ would have enhanced reactivity.

A related hypothesis accounts for catalytic action on the basis of interaction of glucose with buffer components to form a reactive intermediate. Formation of products of this type in appreciable concentration has been ruled out polarimetrically for H_3PO_4/NaH_2PO_4 buffers at pH 2.2 and 3.0, but rapid reversible generation of very low concentrations is not thereby excluded.

The available data can be accommodated if general base catalysis is assumed to be operative. The absence in the present work of detectable acceleration by hydroxide ion can be ascribed to its very low concentration. The apparent inertness of SO_4^{2-} (at pH 2.3) may be ascribed to its feeble basicity rendering it incapable of competing with solvent molecules. In such a case, the Brønsted catalysis law⁴⁵ predicts that $H_2PO_4^-$ will be inert as well. The dependence of rate on buffer concentration at pH 3 must then be ascribed to the action of HPO_4^{2-} if Cl_2 is the oxidant. Alternatively, since at pH 3 the proportion of oxidation by $HOCl$ is greater, it may be assumed that attack by this

molecule is more susceptible to catalysis so that $H_2PO_4^-$ (as well as HPO_4^{2-}) is effective.

Speculation concerning the mode of attack of oxidant can be guided not only by kinetics but by the occurrence of selective attack at C_1 in both pyranose aldoses and glycosides. This selectivity virtually eliminates a rate determining reaction with molecular halogen to form alkyl hypohalite⁴⁶ since such a reaction could occur readily at other than the hemiacetal hydroxyl. Equilibrium formation of alkyl hypohalite at various positions followed by a rate controlling decomposition occurring most rapidly at C_1 is eliminated by the observed enhancement of the reaction rate by chloride and hydrogen ions. It can be seen from equation 5 that such a step would lead to inhibition by these ions.

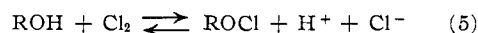

A mechanism involving preliminary alkyl hypohalite formation is, in any case, inapplicable to the glycosides.

The demonstrated existence of complexes of ethers and alcohols with bromine and iodine⁴⁷ suggests a type of mechanism which may hold for both pyranose aldoses and glycosides and which provides a role for base catalysis closely resembling its participation in chromate oxidation.⁴⁸ This consists of processes such as

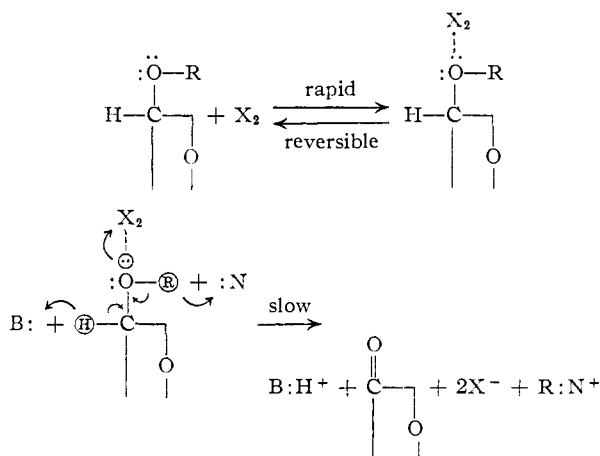

Here B: and N: represent any base, including water, or for the glycosides N: represents any nucleophilic reagent. R is either hydrogen or an alkyl group.

Further work directed toward the testing of this hypothesis is under way in these laboratories.

Acknowledgment.—The authors wish to express their gratitude to the Kendall Co. for a fellowship which supported one of them, to Dr. John Hollister of that organization both for suggesting work in this area and for helpful discussions and to Mr. Gerald J. Grillo for carrying out several of the experiments herein reported.

BOSTON 15, MASSACHUSETTS

(46) L. Farkas, B. Perlmutter and O. Schächter, *THIS JOURNAL*, **71**, 2829 (1949).

(47) R. M. Keefer and L. J. Andrews, *ibid.*, **75**, 3561 (1953).

(48) F. J. Holloway, M. Cohen and F. H. Westheimer, *ibid.*, **73**, 65 (1951).

(37) P. B. D. de la Mare, A. D. Keltey and C. A. Vernon, *J. Chem. Soc.*, 1290 (1954).

(38) D. H. Derbyshire and W. A. Waters, *ibid.*, 564 (1950).

(39) W. J. Wilson and F. G. Soper, *ibid.*, 3376 (1949).

(40) S. Bugarszky, *Z. physik. Chem.*, **48**, 63 (1904).

(41) G. Bogner, *ibid.*, **71**, 529 (1910).

(42) R. O. Griffith, A. McKeown and A. G. Winn, *Trans. Faraday Soc.*, **28**, 107 (1932).

(43) R. O. Griffith and A. McKeown, *ibid.*, **28**, 518 (1932).

(44) R. P. Mauger and F. G. Soper, *J. Chem. Soc.*, 71 (1946); B. S. Painter and F. G. Soper, *ibid.*, 342 (1947).

(45) A. A. Frost and R. G. Pearson, "Kinetics and Mechanism," J. Wiley and Sons, Inc., New York, N. Y., 1953, pp. 210-214.